

Experimental research into uniformity in spreading mineral fertilizers with fertilizer spreader disc with tilted axis

V. Bulgakov¹, O. Adamchuk², S. Pascuzzi³, F. Santoro³ and J. Olt^{4,*}

¹National University of Life and Environmental Sciences of Ukraine, 15 Heroyiv Oborony Str., UA 03041 Kyiv, Ukraine

²National Scientific Centre, Institute for Agricultural Engineering and Electrification, 11 Vokzalna Str., Glevakcha 1, Vasylkiv District, UA 08631 Kyiv Region, Ukraine

³University of Bari Aldo Moro, Department of Agricultural and Environmental Science, Via Amendola, 165/A, IT 70125 Bari, Italy

⁴Estonian University of Life Sciences, Institute of Technology, 56 Kreutzwaldi Str., EE 51006 Tartu, Estonia

*Correspondence: jyri.olt@emu.ee

Received: Received: February 2nd, 2021; Accepted: March 27th, 2021; Published: April 7th, 2021

Abstract. Improving the efficiency in the work process of mineral fertilizer dressing is a topical problem in today's agricultural industry. The authors have developed a design of the fertilizer spreading tool with a tilted axis and carried out field experiment investigations on it. It has been established by the results of the investigations that the non-uniformity in the spreading of mineral fertilizers along the line of their departure from the fertilizer spreading tool with a tilted axis is most strongly affected by the disc rotation frequency. The obtained results provide for selecting the optimum parameters and modes of operation for the tool under consideration in the situation, when it is installed in fertilizer placing machines. Also, it has been established that increasing the spreading disc rotation frequency in such a tool from 600 to 800 rpm results in the growth of the effective range of mineral fertilizer spreading along the placing line at a level of 10.5 m. Increasing the disc's angle of inclination to the horizontal plane to 20° results in the rise of the effective fertilizer spreading range at a level of the 48th tray (24 m) inclusive as well as the increase of the distance between the tool and the tray that contains the maximum share of the spread fertilizers (5.1%) to 24 trays (12 m). At a constant rotation frequency of the disc in the tilted-axis fertilizer spreading tool, in all its kinematic modes of operation, an increase in the angle of its disc's inclination to the horizontal plane results in the rise of the indices representing the distribution of the mineral fertilizers over the trays along the line of their placing. The width of the mineral fertilizer spreading can be controlled by adjusting the rotation frequency of the disc in the tilted-axis fertilizer spreading tool, when it is set at an angle to the horizontal plane, similar to how it is done in state-of-the-art fertilizer placing machines with horizontally positioned discs in their centrifugal spreading tools. The rotation frequency of the disc in the tilted-axis fertilizer spreading tool has the most significant effect on the coefficient of variation incidental to the distribution of the mineral fertilizers along the line of their placing.

Key words: disc, inclination, mineral fertilizer, uniformity, spreading tool.

INTRODUCTION

It is common knowledge that the dosage provided in the mechanical spreading of mineral fertilizers and the uniformity in their distribution over the soil surface have an effect not only on the yield of the cultivated crops, but also on the quality of the harvest. In particular, the reduction of the non-uniformity in the fertilizer spreading from 30% to 15% results in the crop loss abatement from 8.6–22.4% to 0.6–1.1% (Adamchuk, 2002; 2006). The above-said implies that the lower the non-uniformity, with which the machines spread fertilizers, is, the greater the effect of their application will be. However, the realia of the development of new machines have proved that attempts to reduce the non-uniformity in the fertilizer spreading result in the need to design more sophisticated and more expensive equipment and that creates the economic situation, where the machinery for dressing the soil with mineral fertilisers and chemical soil improvers has low productive capacity and operating and economic efficiency.

Such a situation sets the research and engineering problem of improving the production output of the mineral fertiliser and chemical soil improver placing machines and reducing the costs per unit in the performance of the respective work process.

The issues related to the improvement of efficiency in the work process of dressing the soil with mineral fertilisers have always been and still is a topical problem. The earlier completed research (Yasenetsky & Sheychenko, 2002; Kobets et al., 2017) has established that the efficiency of the mineral fertiliser dressing depends not only on the fertilisers themselves, but on the methods of their placing as well. The primary factor limiting the efficiency of mineral fertiliser dressing is the non-uniformity in the distribution of the fertilisers over the area of the field (Yildirim, 2006; Lawrence et al., 2007; Villette et al., 2007; 2008; Jones et al., 2008; Marinello et al., 2017). It has a material effect on the ripening of the crop, causes variation in the yield and, overall, results in the decrease of the harvest (Adamchuk, 2002).

At the same time, the efficiency of mineral fertiliser application is also affected by the depth of fertiliser placement in the soil. According to the results of the completed investigations, it has been established that the placement of mineral fertilisers in the soil at a depth of 18–24 cm results in their unavailability for the plants in their initial growth period, while during the ripping of the soil with various harrows and cultivators the nutrient substances get stirred and become placed mostly in the upper drying soil layer (0–6 cm), where they are again not fully available for the plants. Many scientists have proved that the drilled fertilizers must become the direct source of nutrients for the plants and they have to be placed in the soil in such a way that they are readily available for the active parts of the agricultural plants' root systems. Placing the fertilisers close to the plant roots establishes a zone of the increased concentration of nutrients, which facilitates their absorption and improves the efficiency of their application. It has been proved that mineral fertilisers have to be placed in both the upper and deeper soil layers, with the concentration that is commensurate with the plant root system development level.

The theoretical and experimental research into the centrifugal-type spinning-disk fertiliser spreading tools has been undertaken by many scientists (Scheufle & Bolwin, 1991; Dintwa et al., 2004; Villette et al., 2005; Olt & Heinloo, 2009; Šima et al., 2013). They have studied the effect that the structural solution of the disks (Villette et al., 2005; Lü et al., 2016; Liu et al., 2018), vanes and other parts of the fertiliser spreading tool design (Grift et al., 2006; Yildirim, 2008), the parameters and modes of their operation

(Van Liedekerke et al., 2009; Villette et al., 2010; Bulgakov et al., 2020), the physical and mechanical properties of the mineral fertilisers and chemical soil improvers and the conditions (Aphale et al., 2003; Villette et al., 2007; Hijazi et al., 2010; Biocca et al., 2013; Šima et al., 2013; Antille et al., 2015), in which the mineral fertiliser spreading machines operate, have on their effective working width, in particular, on the spreading range, the fertiliser placing non-uniformity etc. However, the schematic models and parameters of centrifugal-type spinning-disk tools discussed in these studies do not take into account the factor of tilting the disc axis in the longitudinal and vertical plane. At the same time, the significance of that factor was proved during the research into the process of spreading mineral fertilisers with the new centrifugal-type fertiliser spreading tool, in which the axes are set with tilt, earlier carried out by the authors.

The aim of this study was to improve the efficiency of the work process of placing mineral fertilisers with centrifugal-type spinning-disk fertiliser spreading tools, in which the disc axes are installed with tilt.

MATERIALS AND METHODS

The authors have designed and produced a mobile version of the experimental unit for research into the mineral fertiliser spreading with the use of centrifugal-type spinning-disk fertiliser spreading tools with tilted rotation axes. The design layout of the experimental unit is presented in Fig. 1, its general appearance is shown in Fig. 2.

On the sliding frame 3 of the experimental unit (Fig. 1), the supply bin 7 (not shown in Fig. 2) is installed, which can be turned in the horizontal plane due to the turning frame 5. In the bottom of the bin 7, there is a seeding hole equipped with the slide valve 8 used for the controlled change of the open area in the said hole. The design of the drive that rotates the tilted-axis fertiliser spreading tool 9 provides for both variation of its rotation frequency and adjustment of the disc inclination angle to the horizontal plane.

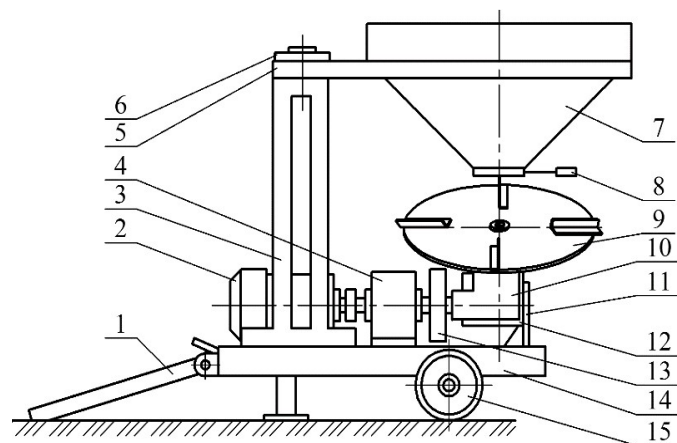

Figure 1. Schematic model of experimental unit for research into mineral fertiliser spreading: 1 – transporting bracket; 2 – electric motor; 3 and 5 – sliding and turning frames, respectively; 4 – chain variable-speed gear; 6 – frame turn swivel; 7 – bin; 8 – slide valve; 9 – fertiliser spreading tool; 10 – bevel-gear speed reducer; 11 and 12 – brackets; 13 – free-wheel clutch; 14 – main frame; 15 – carrier wheel.

The work process of the experimental unit is as follows. The torque of the motor 2 is transmitted via the coupling to the input shaft of the chain variable-speed gear 4 that changes the rotation frequency. The output shaft of the gear drives via the free-wheel clutch the rotary motion of the input shaft in the bevel-gear speed reducer 10. As a result of that process, the rotary motion is imparted to the output shaft of the bevel-gear speed reducer 10, on which the fertiliser spreading tool with a tilted axis is installed. The

mineral fertilisers are seeded down from the bin 7 under the action of the gravity force through the seeding hole's open area and arrive in metered amount onto the fertiliser spreading tool 9, the axis of which is set with tilt, where they are captured by the vanes fixed on the disc. When the mineral fertiliser particles get onto the vanes, they accelerate under the action of the centrifugal force, moving along the vanes from the centre of the disc to their peripheral ends. After the mineral fertilisers reach the peripheral ends of the vanes, they depart from the vanes and, on account of the received reserve of kinetic energy, perform free motion in the air along a certain trajectory directed away from the fertiliser spreading tool, the axis of which is set with tilt with respect to the surface of the horizontal site, where the experimental investigations are carried out.



Figure 2. Experimental unit for research into process of mineral fertiliser top dressing with the use of centrifugal-type spinning-disk fertiliser spreading tools with tilted axes, with standard trays placed along the line of spreading.

During the completed experimental investigations, the mineral fertilisers spread with such a fertiliser spreading tool were collected in standard trays sized $0.5 \times 0.5 \times 0.1$ m. The trays were placed tightly close to each other, thus preventing any loss of the mineral fertiliser particles falling from above at various angles to the horizontal plane. Each of the trays was placed at a strictly controlled distance from the experimental unit, that is, when the trays were placed along the line of spreading, they were all situated on a straight line with insignificant spacing from each other. Their total number on the line was equal to 80. That corresponded to a mineral fertiliser particle collection distance of more than 40 m.

Similarly, experimental investigations were carried out with the use of the machine equipped with two fertiliser spreading tools of the same design, the axes of which were set at an angle to the horizontal plane. In this case, again, all the trays were placed along the two directions of spreading in the same way, sufficiently close to each other and over a distance of 40 m in the two directions (Fig. 3).



Figure 3. General appearance of the experimental mineral fertiliser top dressing machine with two fertiliser spreading tools, axes of which were set at an angle to horizontal plane, during the field experiment investigations, in which trays were placed along the two directions of spreading.

The field experiment investigations were carried out with the use of the following mineral fertiliser: ‘Ammonium saltpetre’ (chemical formula NH_4NO_3 , nitrogen content 34.7%).

The physical and mechanical properties of it were as follows:

1. Average moisture content – 0.17%;
2. Bulk density – 780 kg m^{-3} ;
3. Density – $1,500 \text{ kg m}^{-3}$;
4. Mean diameter of particles - 1.34 mm;
5. Percentage of size fractions: 0 to 0.5 mm – 13.1%; 1 to 2 mm – 83.5%; 2 to 3 mm – 3.4%;
6. Flight velocities of particles by size: < 1.0 mm – 2.2 to 4.9 m s^{-1} ; 1 to 2 mm – 4.1 to 7.9 m s^{-1} ; 2 to 3 mm – 5.6 to 8.3 m s^{-1} ;
7. Coefficient of friction on steel: 0.3 to 0.6.

In order to investigate the effect that the rotation frequency of the spreading tool and the angle of its inclination with respect to the horizontal plane have on the non-uniformity in the distribution of the mineral fertilisers along the line of their placing (i.e. along the line that is perpendicular to the axis of the experimental unit), the two-factor experiment with several levels of the factor variation was designed and carried out. In the experiment, the non-uniformity of mineral fertiliser spreading was measured by the coefficient of variation of the mineral fertiliser distribution over the standard trays.

The mathematical formulation of the processes was performed in the form of generating regression equations. For that purpose, the following factors had been selected:

n – rotation frequency of the disc in the fertiliser spreading tool with a tilted axis, in natural units;

α – disc’s angle of inclination to the horizontal plane, in natural units;

X_1 – rotation frequency of the disc, in encoded form;

X_2 – disc’s angle of inclination to the horizontal plane, in encoded form.

The experimental investigation of the non-uniformity in the distribution of the mineral fertilisers spread by the fertiliser spreading tool with a tilted axis along the line of their placing was carried out in accordance with the mathematical design of the multiple-factor experiment following the prepared design matrices (Tables 1 and 2).

The data obtained as a result of the experimental investigations were processed with the aim of generating the regression model that would describe the effect of the factors and their interrelations on the non-uniformity in the spreading of mineral fertilisers by the fertiliser spreading tool with a tilted axis into the trays along the line of their placing, with the use of standard techniques of statistical processing.

Table 1. Design matrix of full factorial experiment for research into non-uniformity in spreading of granulated superphosphate by fertiliser spreading tool with a tilted axis along line of its placing

No.	Factor values: in natural (coded) form	
	n [rpm] (X_1)	α [deg] (X_2)
1	600 (–1)	30 (–2)
2	600 (–1)	20 (–1)
3	600 (–1)	10 (0)
4	600 (–1)	0 (+1)
5	800(0)	30 (–2)
6	800(0)	20 (–1)
7	800(0)	10 (0)
8	800(0)	0 (+1)
9	1,000 (+1)	30 (–2)
10	1,000 (+1)	20 (–1)
11	1,000 (+1)	10 (0)
12	1,000 (+1)	0 (+1)

At the first stage of processing the experimental data, after their acquisition, they were checked for repeatability. In order to assess the repeatability, Cochran's test was applied, the value of the criterion was determined with the use of the relation:

$$G = \frac{S_{u \max}^2}{\sum_{u=1}^n S_u^2} \leq G_t \quad (1)$$

where $G_t(0.05; n; f_u)$ – table value of Cochran's criterion at a significance level of 5%, the number of experiments n and the number of degrees of freedom $f_u = m - 1$ with the number of replications m .

The variance was determined with the use of the following expression:

$$S_u^2 = \frac{1}{m-1} \sum_{i=1}^m (y_{uik} - \bar{y}_u)^2, \quad (2)$$

where y_{uik} – value of the output variable in the respective replication.

Further, the experimental error was calculated as follows:

$$S_y^2 = \frac{1}{n} \sum_{u=1}^n S_u^2 \quad (3)$$

If the checking with the use of the Cochran's test proved that the process was repeatable, the next step in the experimental data processing would be to find the regression coefficients in accordance with the following formulae:

$$\begin{aligned} b_0 &= \frac{1}{n} \sum_{i=1}^n \bar{y}_u, \\ b_p &= \frac{1}{n} \sum_{i=1}^n X_p \bar{y}_u, \\ b_{pr} &= \frac{1}{n} \sum_{i=1}^n X_p X_r \bar{y}_u. \end{aligned} \quad (4)$$

The adequacy of the regression equation was checked with the use of Fisher's ratio test:

$$F = \frac{S_{ad}^2}{S_y^2} < F_t \quad (5)$$

where $S_{ad}^2 = \frac{1}{f_{ad}} \sum_{u=1}^n (y - \bar{y}_u)^2$ – adequacy variance; $f_{ad} = n - k - 1$ – number of degrees of freedom of the adequacy variance in case of the number of factors equal to k ; $f_y = n(m - 1)$ – number of degrees of freedom of the repeatability variance.

The next step was to assess the significance of the coefficients in the regression equation with the use of Student's test. The criterion of the regression equation coefficient's significance was formulated as follows:

Table 2. Design matrix of full factorial experiment for research into non-uniformity in spreading of nitroammophoska and ammonium saltpetre by fertiliser spreading tool with a tilted axis along line of its placing

No.	Factor values: in natural (coded) form	
	n [rpm] (X_1)	α [deg] (X_2)
1	600 (-1)	30 (-2)
2	600 (-1)	20 (-1)
3	600 (-1)	0 (+1)
4	800 (0)	30 (-2)
5	800 (0)	20 (-1)
6	800 (0)	0 (+1)

$$|b_i| \geq t_t \cdot \frac{S_y}{\sqrt{n}} \quad (6)$$

where t_t – table value of Student's criterion at a significance level of 5%.

The correlation analysis of the data under consideration was aimed at establishing the presence of a relationship between the factors.

The coefficient of the correlation between the values x and y was determined as follows:

$$r_{xy} = \frac{K_{xy}}{S_x S_y} \quad (7)$$

where S_x, S_y – mean deviations of the respective values; K_{xy} – covariance.

If the correlation coefficient is equal to zero, the values are uncorrelated, in case the correlation coefficient is above 0.7, the correlation is strong, at 0.3–0.7 – moderate, at correlation coefficient values below 0.3 – weak.

The root-mean-square error of the correlation coefficient was determined with the use of the following expression:

$$S_r = \sqrt{\frac{1 - r_{xy}^2}{n - 2}} \quad (8)$$

The correlation between the parameters is significant provided that the calculated value of Student's criterion exceeds its table value. That is:

$$t_r = \frac{r_{xy}}{S_r} \geq t_t \quad (9)$$

The laboratory investigations were carried out with the following values of the main operating conditions of the experimental unit and the design parameters of the fertiliser spreading tool with a tilted axis:

- rotation frequency of the disc in the fertiliser spreading tool with a tilted axis: 600 rpm, 800 and 1,000 rpm;
- angle of the disc's inclination with respect to the horizontal plane: 0°, 10°, 20°, 30°;
- diameter of the disc – 650 mm;
- fertiliser seeding radius – 150 mm.

The non-uniformity in the distribution of the mineral fertiliser was measured by the coefficient of variation:

$$v = \frac{100\sigma}{M} \quad (10)$$

where σ – mean deviation; M_i – mass of the fertiliser particles in the i^{th} tray; k – number of trays.

RESULTS AND DISCUSSION

In accordance with the results of the experimental investigations, the effect of the rotation frequency of the disc in the fertiliser spreading tool with a tilted axis on the pattern of distribution in the spreading of ammonium saltpetre along the line of its placing has been established and the graphic relations presented in Fig. 4 have been plotted. For that purpose, two fixed disc rotation frequencies have been selected - 600 and 800 rpm. Such a selection is justified by the following facts. Rotation frequencies

below 600 rpm cannot provide the mineral fertiliser particles that slip off the vane on the spreading disc with sufficient departure velocities. Consequently, the distances flown by the particles until they touch the ground are automatically shorter in this case. On the other hand, when the spreading disc rotates with a frequency exceeding 800 rpm, the processes of the fertiliser spreading tool vane accelerating the ammonium saltpetre granules and the granules falling on the ground result in the break-up of the granules, which is unacceptable in terms of the agronomical requirements to the top dressing and also, in case the break-up happens on the disc, considerably reduces the distance flown by the broken saltpetre granules. Hence, the experimental investigations have been carried out with the use of the two fixed rotation frequencies of the experimental fertiliser spreading tool with a tilted axis, one of them - the minimum acceptable one and the second - the maximum acceptable one.

In the experimental investigations, it has been established that the horizontal position of the spreading disc rotating with a frequency of 600 rpm stipulates the effective range of spreading ammonium saltpetre along the line of its placing to reach the 30th tray inclusive (15 m), the maximum fraction of the discharged fertiliser (7.2%) being seeded into the 12th tray (6 m). Increasing the rotation frequency of the disc in the fertiliser spreading tool with a tilted axis to 800 rpm results in the increase of the length of the effective ammonium saltpetre spreading area to the 35th tray inclusive (17.5 m). In this case, the maximum fraction of the fertiliser (6.3%) is seeded into the 15th tray (7.5 m).

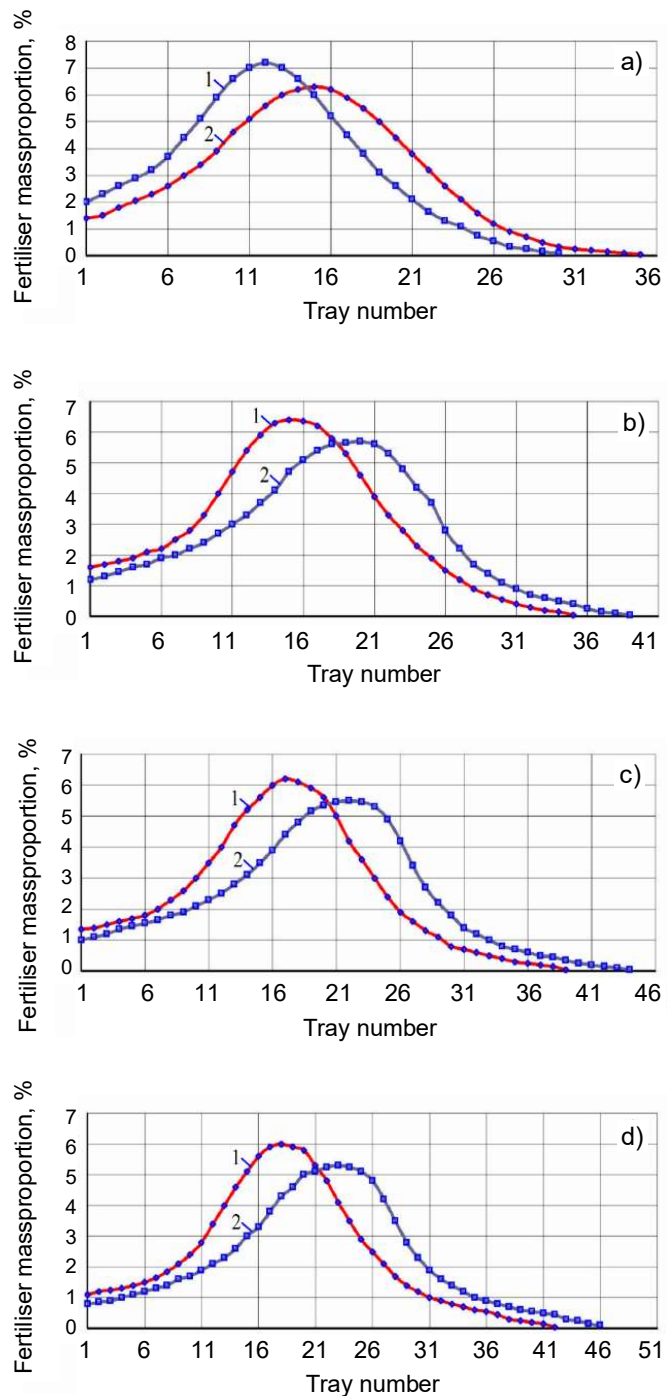

Figure 4. Relation between distribution of ammonium saltpetre spread by fertiliser spreading tool with tilted axis along line of its placing in trays and disc rotation frequency: a, b, c, d – disc's angles of inclination to horizontal plane, respectively: 0°, 10°, 20°, 30°; 1, 2 – disc's rotation frequency, respectively: 600 and 800 rpm.

Hence, when the disc in the fertiliser spreading tool is in the horizontal position, increasing its rotation frequency from 600 to 800 rpm results in the rise of the effective ammonium saltpetre spreading range by 16.7%, also the distance from the fertiliser spreading tool to the tray, into which the maximum mass dose of fertiliser is seeded rises by 25%, while the maximum mass fraction of fertiliser seeded into one tray decreases by a factor of 1.14.

Similar patterns with regard to the effect of the rotation frequency of the disc in the fertiliser spreading tool with a tilted axis on the distribution of the spread ammonium saltpetre along the line of its placing are also observed in case of an increase in the disc's angle of inclination with respect to horizontal plane to 30° (Fig. 5). As is seen in the presented graphic relations, the curve 2 representing the ammonium saltpetre distribution pattern at a disc rotation frequency of 800 rpm is significantly shifted to the right as compared to the curve 1 corresponding to the ammonium saltpetre distribution pattern at a disc rotation frequency of 600 rpm. Hence, it is appropriate to analyse the effect of the changes in the angle, at which the disc of the fertiliser spreading tool with a tilted axis is set with respect to the horizontal plane, on the distribution characteristics incidental to the spreading of ammonium saltpetre into the trays along the line of its placing.

When the spreading disc in the fertiliser spreading tool with a tilted axis rotates with a frequency equal to 600 rpm and is installed at an angle of 10° to the horizontal plane (Fig. 5), ammonium saltpetre is effectively spread within the area up to the 35th tray (18.5 m) inclusive, while the maximum fraction of the fertiliser (6.4%) is seeded into the 15th tray (7.5 m). In the case of setting the disc at an angle of 20° to the horizontal plane, the effective spreading of ammonium saltpetre is performed within the area up to the 39th tray (19.5 m) inclusive and the maximum mass fraction of the fertiliser (6.2%) is seeded into the 17th tray (8.5 m). Increasing the angle of the disc's inclination with respect to the horizontal plane to 30° results in the increase of the effective ammonium saltpetre spreading range to the 42nd tray (21 m) inclusive, the maximum mass fraction of the fertiliser (6%) being seeded into the 18th tray (9 m).

Thus, it has been established that, in case the disc in the fertiliser spreading tool with a tilted axis rotates with a frequency of 600 rpm, the change in the setting angle of the disc in the said tool from 0° to:

- 10° results in the increase of the effective ammonium saltpetre spreading range by 16.7% and the distance from the fertiliser spreading tool with a tilted axis to the tray with the maximum mass fraction of the seeded fertiliser - by 25%, while the above-mentioned mass fraction of ammonium saltpetre decreases by a factor of 1.13;

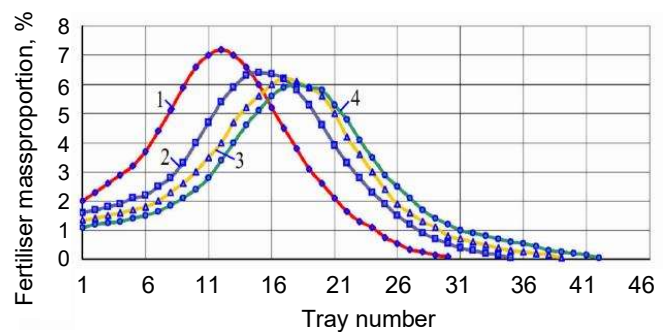

Figure 5. Relation between distribution of ammonium saltpetre spread by fertiliser spreading tool with tilted axis along line of its placing in trays at disc rotation frequency of 600 rpm and angle of disc's inclination with respect to horizontal plane: 1, 2, 3, 4 – disc's angle of inclination with respect to horizontal plane is equal to, respectively: 0°, 10°, 20°, 30°.

- 20° results in the increase of the effective ammonium saltpetre spreading range by 30% and the distance from the fertiliser spreading tool with a tilted axis to the tray with the maximum mass fraction of the seeded fertiliser - by 41.7%, while the above-mentioned mass fraction of ammonium saltpetre decreases by a factor of 1.16;
- 30° results in the increase of the effective ammonium saltpetre spreading range by 40% and the distance from the fertiliser spreading tool with a tilted axis to the tray with the maximum mass fraction of the seeded fertiliser - by 50%, while the above-mentioned mass fraction of ammonium saltpetre decreases by a factor of 1.2.

When the disc in the fertiliser spreading tool with a tilted axis rotates with a frequency equal to 800 rpm and is installed at an angle of 10° to the horizontal plane (Fig. 6), ammonium saltpetre is effectively spread within the area up to the 39th tray (19.5 m) inclusive, while the maximum mass fraction of the fertiliser (5.7%) is seeded into the 20th tray (10 m). In the case, when the disc is set at an angle of 20° to the horizontal plane, the effective spreading of ammonium saltpetre is performed within the area up to the 44th tray (22 m) inclusive, the maximum mass fraction of the fertiliser (5.5%) is seeded into the 22nd tray (11 m). Increasing the angle of the disc's inclination with respect to the horizontal plane to 30° results in the increase of the effective ammonium saltpetre spreading range to the 47th tray (23.5 m) inclusive, the maximum mass fraction of the fertiliser (5.3%) being seeded into the 23rd tray (11.5 m).

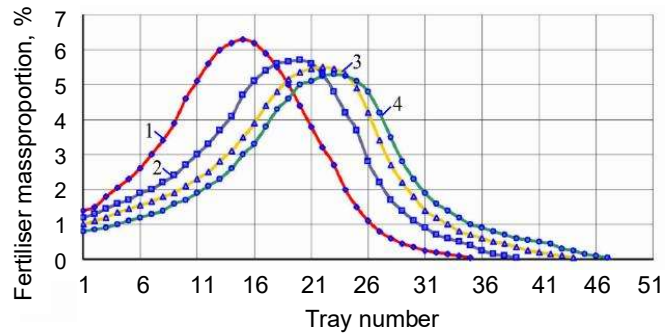

Figure 6. Relation between distribution of ammonium saltpetre spread by fertiliser spreading tool with tilted axis along line of its placing in trays at disc rotation frequency of 800 rpm and angle of disc's inclination with respect to horizontal plane: 1, 2, 3, 4 – disc's angle of inclination with respect to horizontal plane, respectively: 0°, 10°, 20°, 30°.

It has been established that, in case the disc in the fertiliser spreading tool with a tilted axis rotates with a frequency of 800 rpm, the change in the disc setting angle from 0° to:

- 10° results in the increase of the effective ammonium saltpetre spreading range by 11.4% and the distance from the fertiliser spreading tool with a tilted axis to the tray with the maximum mass fraction of the seeded fertiliser - by 33.3%, while the above-mentioned mass fraction of ammonium saltpetre decreases by a factor of 1.1;
- 20° results in the increase of the effective ammonium saltpetre spreading range by 25.7% and the distance from the fertiliser spreading tool with a tilted axis to the tray with the maximum mass fraction of the seeded fertiliser - by 46.7%, while the above-mentioned mass fraction of ammonium saltpetre decreases by a factor of 1.15;
- 30° results in the increase of the effective ammonium saltpetre spreading range by 34.3% and the distance from the fertiliser spreading tool with a tilted axis to the tray with the maximum mass fraction of the seeded fertiliser - by 53.3%, while the above-mentioned mass fraction of ammonium saltpetre decreases by a factor of 1.19.

The results of the research into the distribution of the ammonium saltpetre spread by the fertiliser spreading tool with a tilted axis along the line of its placing over the trays prove that increasing the disc rotation frequency from 600 to 800 rpm results, within the whole range of values used in the research for the angle, at which the disc in the fertiliser spreading tool with a tilted axis is set with respect to the horizontal plane, in the rise of both the effective ammonium saltpetre spreading range and the distance from the fertiliser spreading tool with a tilted axis to the tray with the maximum mass fraction of the seeded fertiliser. For example, the increase in the effective ammonium saltpetre spreading range is in case of an angle of $0^\circ - 16.7\%$, $10^\circ - 11.4\%$, $20^\circ - 12.8\%$, $30^\circ - 11.9\%$, while the distance from the fertiliser spreading tool with a tilted axis to the tray with the maximum mass fraction of the seeded fertiliser increases at the following angles of inclination by: $0^\circ - 25.0\%$, $10^\circ - 33.3\%$, $20^\circ - 29.4\%$, $30^\circ - 27.8\%$.

In case of the disc in the fertiliser spreading tool with a tilted axis rotating at a constant frequency, in all kinematic modes of operation of the tool, increasing the tool disc setting angle to the horizontal plane results in the improved indicators of the distribution of ammonium saltpetre over the trays along the line of its placing. In particular, when the disc in the fertiliser spreading tool with a tilted axis rotates at a frequency of 800 rpm, the rise in the effective ammonium saltpetre spreading range due to the increase in the angle of inclination of the disc in the fertiliser spreading tool with a tilted axis, as compared to its horizontal position, to 10° has a value of 11.4% , $20^\circ - 25.7\%$, $30^\circ - 34.3\%$, the respective rise in the distance from the fertiliser spreading tool with a tilted axis to the tray with the maximum mass fraction of the seeded fertiliser is equal to: $10^\circ - 33.3\%$, $20^\circ - 46.7\%$, $30^\circ - 53.3\%$.

The above-stated proves that the parameter of the rotation speed of the disc in the fertiliser spreading tool with a tilted axis can be used for controlling the ammonium saltpetre spreading range also in case, when the disc is set at an angle to the horizontal plane, the same as it is done in state-of-the-art fertiliser placing machines with horizontally set discs in their fertiliser spreading tools.

Increasing the angle of the disc's inclination with respect to the horizontal plane results in the rise of the indicators representing the ammonium saltpetre spreading range and the working width of the mineral fertiliser placing machine. At the same time, the rate of increase of the above-mentioned indicators is at its peak, when the angle of the disc's inclination with respect to the horizontal plane rises from 0° to 10° . After that, it declines, as the angle grows up to 30° .

The fertiliser spreading tool with a tilted axis ensures spreading ammonium saltpetre along the line of its placing to greater distances, than in case of the fertiliser spreading tool with a vertical rotation axis. That proves the hypothesis of a possibility to increase the working width of mineral fertiliser placing machines by means of equipping such machines with fertiliser spreading tools with tilted axes.

The regression equations that describe the effect of the disc's rotation frequency and its angle of inclination with respect to the horizontal plane on the non-uniformity in the distribution of ammonium saltpetre along the line of its placing appear as follows:

$$y = -101.4 - 0.0574n + 4.6034\alpha - 0.0256\alpha^2. \quad (11)$$

It has been established by analysing the relation (11) that the non-uniformity in the placing of ammonium saltpetre along the line of its departure from the fertiliser

spreading tool with a tilted axis is affected most of all by the value of the disc rotation frequency.

In a similar way, the regression equations that describe the distribution patterns for the spreading of granulated superphosphate along the line of its placing by the fertiliser spreading tool with a tilted axis have been obtained:

$$y = 18.2533 + 0.0992n - 0.3063\alpha - 0.000092n^2 + 0.0037\alpha^2 + 0.00011n\alpha. \quad (12)$$

It has been established by analysing the obtained regression (12) that the most significant effect on the coefficient of variation of the granulated superphosphate distribution along the line of its placing is, again, produced by the rotation frequency of the disc in the fertiliser spreading tool with a tilted axis.

As a result of implementing the two-factor experiment, the following relation between the coefficient of variation of the nitroammophoska distribution along the line of its placing, on the one hand, and the angle of inclination to the horizontal plane of the disc in the fertiliser spreading tool with a tilted axis and its rotation frequency, on the other hand, has been obtained:

$$y = 80.46 - 0.0312n - 0.3825\alpha - 0.000037n^2 + 0.0018\alpha^2 + 0.00046n\alpha. \quad (13)$$

In a similar way to the results of the analysis of the expressions (11) and (12), it has been established that the most important factor with regard to the effect on the non-uniformity in the spreading of nitroammophoska along the line of its departure from the fertiliser spreading tool with a tilted axis is the disc rotation frequency.

The obtained results provide for selecting the optimum parameters and modes of operation for the fertiliser spreading tool with a tilted axis, when it is operated as part of a fertiliser placing machine. However, it is to be taken into consideration that, in case of a machine equipped with two fertiliser spreading tools with tilted axes, where the fertiliser is spread from each of the tools not in the form of a separate strip, but in the form of a fan with an angle at centre of circa 90°, it is necessary to carry out field experiments, in which a tractor with the fertiliser placing machine will pass the control plot, where the trays for the collection of the seeded mineral fertilisers are placed following the standard procedure, in order to obtain the data on the non-uniformity in the spreading of fertilisers within the working width of the machine.

CONCLUSIONS

1. Increasing the frequency of the disc rotation in the fertiliser spreading tool with a tilted axis from 600 to 800 rpm results in the growth of the effective range of spreading mineral fertilisers along the line of their placing at a level of 10.5 m. Increasing the angle of the disc's inclination with respect to the horizontal plane to 20° results in a rise in the effective fertiliser spreading range at a level of the 48th tray (24 m) inclusive as well as an increase in the distance from the fertiliser spreading tool with a tilted axis to the tray with the maximum mass fraction of the seeded fertiliser (5.1%) to the 24th tray (12 m).

2. If the disc in the fertiliser spreading tool with a tilted axis rotates at a constant frequency, in all kinematic modes of the tool operation, increasing the tool disc setting angle with respect to the horizontal plane results in an improvement of the indicators that represent the distribution of the mineral fertilisers over the trays along the line of their placing.

3. The mineral fertiliser spreading range can be controlled by changing the rotation frequency of the disc in the fertiliser spreading tool with a tilted axis, when the disc is set at some angle to the horizontal plane, similarly to how it is done in state-of-the-art fertiliser placing machines, where the disc in the centrifugal tool is in the horizontal position.

4. Increasing the disc's angle of inclination to the horizontal plane results in the growth of the indicators that represent the range of spreading mineral fertilisers and the working width of the machine for their placing. In this growth, the increase in the above-mentioned indicators is most intensive, when the angle of the disc's inclination to the horizontal plane rises from 0° to 10°, but it declines during the further rise of the angle up to 30°.

5. The factor that has the most significant effect on the coefficient of variation incidental to the distribution of mineral fertilisers along the line of their placing is the rotation frequency of the disc in the fertiliser spreading tool with a tilted axis.

REFERENCES

- Adamchuk, V. 2006. *Mechanical-technological and technical bases of increase of efficiency of introduction of firm mineral fertilizers and chemical fertilizers*. The Abstract of the Dissertation of the Doctor of Technical Sciences. National Agrarian University. Kyiv, 40 pp. (in Ukrainian).
- Adamchuk, V. 2002. Substantiation of the model of application of mineral fertilizers. Interagency thematic scientific collection. *Mechanization and electrification of agriculture* **86**, 90–99 (in Ukrainian).
- Antille, D.L., Gallar, L., Miller, P.C.H. & Godwin, R.J. 2015. An investigation into the fertilizer particle dynamics off the disc. *Applied Engineering in Agriculture* **31**(1), 49–60.
- Aphale, A., Bolander, N., Park, J., Shaw, L., Svec, J. & Wassgren, C. 2003. Granular fertiliser particle dynamics on and off a spinner spreader. *Biosystems Engineering* **85**(3), 319–329. doi: 10.1016/S1537-5110(03)00062-X
- Biocca, M., Gallo, P. & Menesatti, P. 2013. Aerodynamic properties of six organo-mineral fertilizer particles. *Journal of Agricultural Engineering* **44**, Art. E83, 411–414.
- Bulgakov, V., Adamchuk, V., Kuvachov, V., Shymko, L. & Olt, J. 2020. A theoretical and experimental study of combined agricultural gantry unit with a mineral fertilizer spreader. *Agraarteadus/Journal of Agricultural Science* **31**(2), 139–146. doi: 10.15159/jas.20.15
- Dintwa, E., Van Liedekerke, P., Olieslagers, R., Tijskens, E. & Ramon, H. 2004. Model for simulation of particle flow on a centrifugal fertiliser spreader. *Biosystems Engineering* **87**(4), 407–415. doi: 10.1016/j.biosystemseng.2004.01.001
- Grift, T.E., Kweon, G., Hofstee, J.W., Piron, E. & Villette, S. 2006. Dynamic Friction Coefficient Measurement of Granular Fertiliser Particles. *Biosystems Engineering* **95**(4), 507–515. doi: 10.1016/j.biosystemseng.2006.08.006
- Hijazi, B., Baert, J., Cointault, F., Dubois, J., Painsavoine, M., Pieters, J. & Vangeyte, J. 2010. A device for extracting 3d information of fertilizer trajectories. In: *XVIIth World Congress of the International Commission of Agricultural and Biosystems Engineering (CIGR)*, Québec City, Canada June 13–17, 8 pp.
- Jones, J.R., Lawrence, H.G. & Yule, I.J. 2008. A statistical comparison of international fertiliser spreader test methods – Confidence in bout width calculations. *Powder Technology* **184**(3), 337–351. doi: 10.1016/j.powtec.2007.09.004
- Kobets, A.S., Naumenko, M.M., Ponomarenko, N.O., Kharytonov, M.M., Velychko, O.P. & Yaropud, V.M. 2017. Design substantiation of the three-tier centrifugan type mineral fertilizers spreader. *INMATEH, Agricultural Engineering* **53**(3), 13–20.

- Lawrence, H.G., Yule, I.J. & Coetzee, M.G. 2007. Development of an image-processing method to assess spreader performance. *Transactions of the ASABE* **50**(2), 397–407.
- Liu, C., Song, J., Zhang, J., Du, X. & Zheng, F. 2018. Design and performance experiment on centrifugal fertilizer spreader with a cone disc. *International Agricultural Engineering Journal* **27**(1), 44–52.
- Lü, J., Shang, Q., Yang, Y., Li, J. & Liu, Z. 2016. Performance analysis and experiment on granular fertilizer spreader with cone disc. *Nongye Gongcheng Xuebao/Transactions of the Chinese Society of Agricultural Engineering* **32**(11), 16–24. doi: 10.11975/j.issn.1002-6819.2016.11.003
- Marinello, F., Pezzuolo, A., Gasparini, F. & Sartori, L. 2017. Integrated approach for prediction of centrifugal fertilizer spread patterns. *Agricultural Engineering International: CIGR Journal* **19**(3), 1–6.
- Olt, J. & Heinloo, M. 2009. On the formula for computation of flying distance of fertilizer's particle under air resistance. *Agraarteadus/Journal of Agricultural Science* **20**(2), 22–25.
- Šima, T., Krupička, J. & Nozdrovický, L. 2013. Effect of nitrification inhibitors on fertiliser particle size distribution of the DASA ® 26/13 and ENSIN ® fertilisers. *Argronomy Research* **11**(1), 111–116.
- Van Liedekerke, P., Tijssens, E. & Ramon, H. 2009. Discrete element simulations of the influence of fertiliser physical properties on the spread pattern from spinning disc spreaders. *Biosystems Engineering* **102**, 392–405. doi: 10.1016/j.biosystemseng.2009.01.006
- Villette, S., Cointault, F., Piron, E., Chopinrt, B. 2005. Centrifugal Spreading: an Analytical Model for the Motion of Fertiliser Particles on a Spinning Disc. *Biosystems Engineering* **92**(2), 157–164. doi: 10.1016/j.biosystemeng.2005.06.013
- Villette, S., Cointault, F., Zwaenepoel, P., Chopinrt, B. & Paindavoine, M. 2007. Velocity measurement using motion blurred images to improve the quality of fertiliser spreading in agriculture. In: *Proceedings of SPIE – The International Society for Optical Engineering*, **6356**, Art. 635601.
- Villette, S., Gée, C., Piron, E., R. Martin, R., Miclet, D. & Paindavoine, M. 2010. Centrifugal fertiliser spreading: velocity and mass flow distribution measurement by image processing. In: *Proceedings of AgEng 2010, International Conference on Agricultural Engineering*, Clermont Ferrand, France, 10 pp.
- Villette, S., Piron, E., Cointault, F. & Chopinet, B. 2008. Centrifugal spreading of fertiliser: Deducing three-dimensional velocities from horizontal outlet angles using computer vision. *Biosystems Engineering* **99** (4), 496–507. doi: 10.1016/j.biosystemseng.2017.12.001
- Yasenetsky, V. & Sheychenko, V. 2002. Mineral spreaders for farms of all forms of ownership. *APK technique* **12**, 16–17 (in Ukrainian).
- Yildirim, Y. 2006. Effect on vane number on distribution uniformity in single disc rotary fertilizer spreaders. *Applied Engineering in Agriculture* **22**(5), 659–663.
- Yildirim, Y. 2008. Effect of vane shape on fertilizer distribution uniformity in single disc rotary fertilizer spreaders. *Applied Engineering in Agriculture* **24**(2), 159–163.