

**Latvia University of Life Sciences and Technologies
Faculty of Engineering**

**17th International Scientific Conference
ENGINEERING FOR RURAL
DEVELOPMENT**

Proceedings, Volume 17

May 23-25, 2018

Jelgava 2018

STABILITY ANALYSIS OF PLATFORMS FOR PICKING FRUIT ACCORDING TO FORTHCOMING STANDARD EN 16952: A CASE STUDY

Francesco Santoro¹, Edmund Lorencowicz², Alexandros Sotirios Anifantis¹, Simone Pascuzzi¹

¹University of Bari Aldo Moro, Italy; ²University of Life Sciences in Lublin, Poland

francesco.santoro@uniba.it, alexandrossotirios.anifantis@uniba.it, simone.pascuzzi@uniba.it

Abstract. Self-propelled machines equipped with mobile elevated platforms able to raise workers and materials are frequently employed for orchard's operations, such as harvesting fruit, pruning operations, opening and closing anti-hail nets and so on. The European standardization Committee (CEN) approved a new specific standard processing, the upcoming EN 16952. This Standard defines the conditions pertinent to different aspects of the mobile aerial platforms and of the automatic control systems in order to have different devices to grant the workers' safety. The main safety requirements and measures provided by the forthcoming standard EN 16952 are analysed and highlighted in this paper.

Keywords: stability analysis, working platforms, safety and health.

Introduction

Self-propelled machines equipped with mobile elevated platforms able to raise workers and materials are frequently employed for orchard's operations, such as harvesting fruit, pruning operations, opening and closing anti-hail nets and so on [1-3]. These machines, which are designed to work on unimproved natural and/or disturbed terrain, are mainly composed by a frame, which supports the wheels and drive components, the lifting mechanism, the working platform and, optionally, the platform lateral extensions [4-7]. The movement of workers and fruit beans on the platform placed at different heights above the soil, also during the machine movement, makes the safety characteristics of this kind of aerial platforms deserving great attention, even if the projection of the centre of gravity of the entire machine always lies inside the tipping lines [8-11]. This typology of agricultural machinery is the object of the forthcoming EC Standard, in draft phase, which has the final aim to specify the relevant safety requirements and measures, so to increase the workplace safety [12-15]. Other machines that could be considered similar with the ones we are dealing with exist, such as the mobile elevating platforms used in the building construction sector [16-19]. The manufacturers of these kinds of machines refer, to comply with the EN "Machinery Directive", to the harmonized technical standard EN 280, which is in force. This European Standard does not fully meet the specific requirements of the agricultural context. For this reason, the European Standardization Committee (CEN) approved a new specific standard processing, the upcoming EN 16952. It is useful to note that the aforesaid EN "Machinery Directive" states that machines, which can raise a work platform to heights greater than 3 m, must be tested by a notified body before obtaining selling authorization, so this Directive should not be applied to the platforms used in agriculture as they always have lower lifting heights. Furthermore, the Italian Law Decree 2008,81 (Safety Consolidated Act) coordinated with the Law Decree 2009,106 compels the final users to have the platforms for orchard operations technically verified every two years. The main innovation of the forthcoming standard EN 16952, the title of which is "Agricultural machinery – Rough-terrain Work Platforms for Orchard's operations (WPO) – Safety", is that it defines the conditions pertinent to different aspects of the mobile aerial platforms and of the automatic control systems, to have different devices to grant the workers' safety [20-25]. Furthermore, in the annex of this standard there are also specified calculations pertinent to the stability and the structure of the WPO, considering that it is the manufacturer's responsibility to evaluate and identify the various positions of the WPO and the combinations of loads that together produce conditions of minimum stability and the most unfavourable stresses in the components. Considering the aforesaid, in the present paper the main safety requirements and measures provided by the forthcoming standard EN 16952 are analysed and an example of stability calculation has been carried out considering the technical data of a WPO available on the Italian market.

Materials and methods

The main requirements fixed by the forthcoming Standard EN 16952

The future standard EN 16952 specifies several safety requirements for the different components of the rough-terrain work platforms for orchard's operations (WPO), also employing suitable

electronic devices connected to a controller able to manage hazard conditions. These guidelines concerning the safety needs are related to the chassis, i.e. the base of the WPO, the extended structure, the work platform, the electrical equipment and the hydraulic systems. Probably, the main change introduced by the referred regulation is the “load limiter”: an automatic control system able to stop the movement of the machine, if the load on the platform exceeds 120 % of the rated load. An electronic system will also control the slope on which the machine is moving forward, automatically stopping in case of exceeding the maximum gradient specified by the manufacturer. Furthermore, an automatic control will automatically activate the power-off brake when the transmission is in neutral. Nowadays, a lot of machines are equipped with the power-off brake (negative brake) that is applied when the engine is turned off: in the future it will be added this functionality to be active with the transmission in the neutral position. As known, in the device the braking is usually generated by springs, which compress fixed alternating tempered steel discs against bronze mobile discs; this thrust is transformed by friction into the braking torque. Brake releasing is achieved by the injection of hydraulic pressure into the brake; the pressure acts upon the piston, which compresses the springs, thus enabling the disc to rotate freely. The brakes are therefore static and closed when the hydraulic pressure is zero and they open when the hydraulic pressure reaches the opening values for release. Also automatic forwarding of the machine will be feasible, that is without requiring the driver to steer continuously, so that this worker would take part in picking fruit in the orchard. It will be possible to angle the barriers of protection against falls of workers from the platform towards the canopy up to 10°, to allow them leaning out without risk. Several general requirements, such as controls, hydraulic plant, protection from moving mechanical parts or parts, which heat up are also highlighted. Finally, experimental dynamic and static tests are required to verify the features of the machine with reference to its stability. For example, the dynamic test provides for the overcoming of obstacles that simulate an outcrop or a hole in the ground. Conversely, the static test must be performed on an inclined plane to assess the degree of the slope. at which the machine starts to overturn.

The WPO considered for the stability calculation

Considering the guidelines of the EN 16952, an example of calculation has been carried to verify the state of minimum stability during the effective operative condition of the work platforms used for fruit harvesting selected among those available on the market: the “Pulcinelli” model PSRF (Figure 1).



Fig. 1. WPO Pulcinelli PSRF 2.4

This machine is fitted with water cooled 3 cylinders, Diesel engine of 20 kW connected to a hydrostatic transmission, 4 drive wheels and an automatic negative brake placed on the transmission. The main sizes reported in Figure 2 highlight the feasibility of the employment of this machine inside Apulian orchards, vineyards and other [26; 27].

This WPO is also equipped with 2 manual lateral extensions one per each side having a length of approximately 1.0 m so that the overall width of the work platform ranges from approximately 1.6 m (both lateral extensions closed) to approximately 3.6 m (both lateral extensions opened) and parallelogram hydraulic elevators, respectively located in the front for loading and at the rear for unloading beans. An inclinometer is present with audible alarm in case of slope exceeding 5 % (2.86°).

To carry out the stability analysis the WPO wheelbase and its rut have been measured as well as the position of the centre of mass has been calculated according to the drawing supplied by the manufacturer. The arrangement of the “all opened” (maximum rise and both lateral extensions opened)

machine has been considered. In this condition, the wheelbase is 1900 mm, the rut 1440 mm, while the position of the centre of mass has been calculated to be 1770 mm above the ground, slightly shifted towards the most loaded front axle in longitudinal direction (35 mm) and towards the steering wheel position side in the lateral direction (15 mm) (Figure 2).

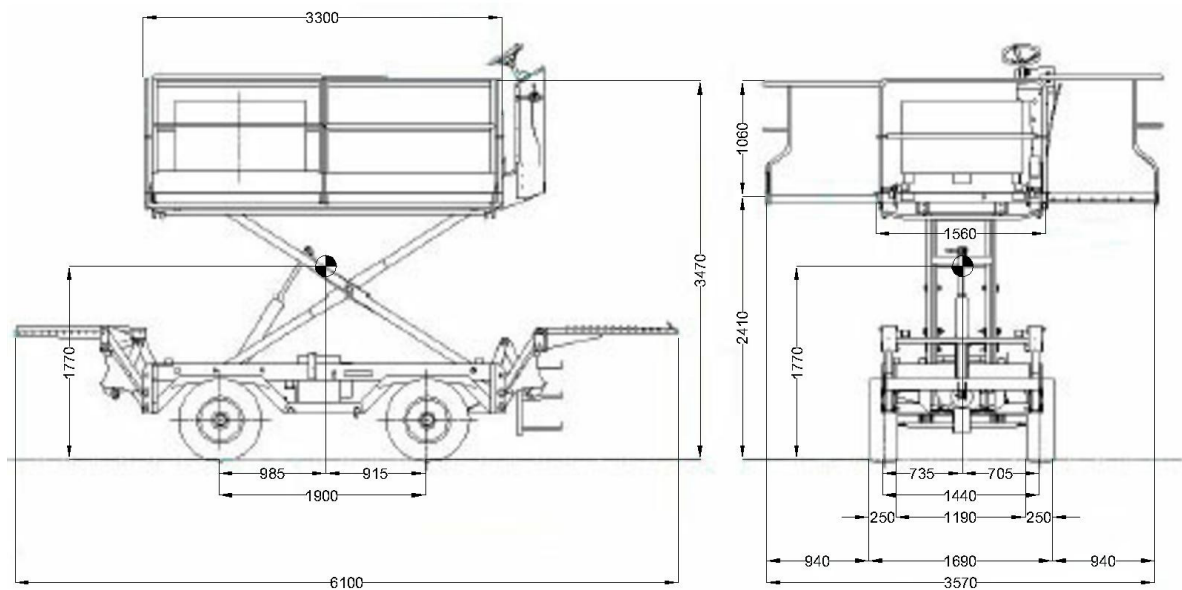

Fig. 2. WPO Pulcinelli PSRF 2.4: main sizes, wheelbase, rut, position of centre of mass

In the agreement with the data provided by the manufacturer, 9800 N is the greatest admissible load on the platform and 4 is the maximum number of persons on it. Furthermore, 2410 mm is the highest height of the platform above the ground; 4000 N the highest admissible manual stress and 13300 N the maximum nominal load. Finally, 12.5 m/s is the admissible wind velocity.

Moreover, the following loads were registered through the experimental measurements (without any additional and external load): overall weight of the WPO: 25900 N; load over the front axle: 13145 N; load over the rear axle: 12755 N.

Loads acting assessment

The EN 16952 European standard establishes that the following five types of loads and forces must be considered for the stability calculations: the rated load, the structural loads, the wind loads, the manual forces, the special loads and forces. Each of these actions will be determined with reference to the considered WPO, in the following according to the standard specification. The position of each of the following loads, both the point load and evenly distributed loads, are represented in Figure 3.

Rated load

The rated load L_R arises considering the loads of persons, tools and bins on the platform, calculated through the following formula even if, for the stability analysis, each of the individual load will be considered alone:

$$L_R = n_p \cdot L_p + L_e + n_b \cdot L_b, \quad (1)$$

where n_p – permitted number of persons on the work platform, calculated as the length of the side of the work platform divided by 1300 mm and rounded;

L_p – load of a person (980 N);

L_e – load of equipment (tools and material) (≥ 390 N: 590 N);

n_b – number of permitted bins on the platform;

L_b – load of a bin (4900 N).

According to the referred standard, the permitted number of persons n_p , on each side of the work platform of the WPO Pulcinelli PSRF 2.4, the length of which is 3300 mm, is given by:

$$n_s = \frac{3330 \text{ mm}}{1300 \text{ mm}} = 2.54 \rightarrow 3 \quad (2)$$

so that the permitted number of persons on the work platform considered for the stability calculation of the WPO should be set equal to 6. This condition is, however, not compatible with the constructive characteristics of the platform itself, as a fence exists in the middle of the longitudinal direction of each of the platform extensions, so it is assumed as stated by the manufacturer, that $n_p=4$.

According with the standard, the load of the tools and materials must be considered as an evenly distributed load not greater than 3 kN/m² acting on a surface not less than the 25 % of the floor of the work platform located in the position giving the most severe results. Considering that the minimum floor work surface of the considered WPO Pulcinelli PSRF 2.4 is 1560 mm x 3300 mm, the maximum evenly distributed load due to the tools and materials is given by

$$L_e = \frac{590}{1.56 \cdot 3.30 \cdot 0.25} = 458.43 \text{ N} \cdot \text{m}^{-2} \quad (3)$$

which does not exceed the 3 kN·m⁻² limitation imposed by the standard.

Referring to the bins for harvested fruit, maximum two of them can be placed simultaneously on the platform, so $n_b=2$.

Furthermore, to perform a more severe stability analysis, it will be assumed that both the front and rear fork-lift are subjected to a load $L_b=4900 \text{ N}$, even if the front fork-lift operates on an empty and lighter bin.

Structural loads

The masses of the components of the mobile elevating work platform must be considered, so for the WPO Pulcinelli PSRF 2.4 a mass of 2640 kg has been considered. For the purpose of the present paper only static, vertical load (L_s) has been considered:

$$L_s = 2640 \cdot g = 2640 \cdot 9.81 \cong 25900.0 \text{ N} \quad (4)$$

Wind loads

The mobile elevating work platform has been considered affected by a horizontal pressure of 100 N/m², which arises by the wind blowing at a speed of 12.5 m·s⁻¹.

The action of the wind on structural elements of the WPO (L_{ws}), on persons (L_{wp}) and on equipment (tools and materials) (L_{we}) has to be considered.

According to the EN16952 standard the wind action on the structural elements L_{ws} should be affected by different values of the shape factor of the amplifying parameters for the different areas exposed to the wind: in order to increase the unfavourable condition increasing the overturning loads, in the following calculations the greater value 1.6 of the shape factor has been considered. Furthermore, for the same reason to increase the overturning loads, the pertinent fence portion of the work platform considered has been taken into account as imperforate to be the value of the surface exposed to the wind, so the height of 1.06 m has been considered both for the lateral and frontal overturning calculations and has been taken into account length of 3.30 m and of 3.57 respectively for the lateral and frontal overturning calculations.

$$L_{wsL} = 100 \text{ N} \cdot \text{m}^{-2} \cdot 3.498 \text{ m}^2 = 349.8 \text{ N} \quad (8a)$$

$$L_{wsF} = 100 \text{ N} \cdot \text{m}^{-2} \cdot 3.784 \text{ m}^2 = 378.4 \text{ N} \quad (8b)$$

When the wind acts on a person, a surface of 0.7 m² (0.4 m average width by 1.75 m average height) has been taken into account regardless the imperforate fence. The wind load on each person on the platform has been given by:

$$L_{wp} = 100 \text{ N} \cdot \text{m}^{-2} \cdot 0.7 \text{ m}^2 = 70.0 \text{ N} \quad (9)$$

Referring to the wind actions on the equipment (tools and materials) according to the standard a load equal to 3 % of their load has been considered:

$$L_{We} = 590 \text{ N} \cdot 0.03 = 17.7 \text{ N} \quad (10)$$

Manual force

The minimum value of L_M manual force, as established by the regulation, must be assumed to be 400 N for mobile elevating work platforms designed to carry more than one person.

Special loads and forces

Special loads and forces are created by particular and non-standard working methods and conditions of use of the mobile elevating work platform. In the particular analysed case, no particular working condition can be highlighted, so no special load or force has been taken into account.

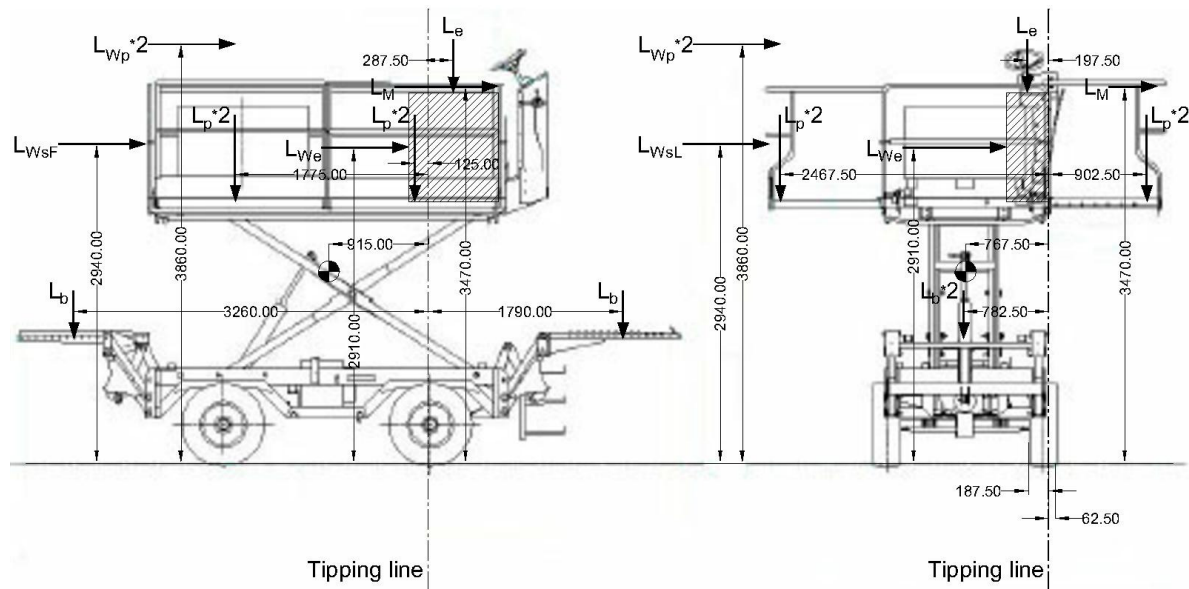

Fig. 3. WPO Pulcinelli PSRF 2.4: load positions

Results

Stability calculations

The maximum overturning and corresponding stabilising moments have been calculated referring to the most unfavourable tipping lines in each working condition. Lateral tipping lines have been placed accordingly with ISO 4305:2014, Annex A, at 1/4 of the tyre ground contact width from the outside of the ground contact width, while the frontal tipping line has been considered passing from the wheel centre as reported in Figure 3.

The calculations have been carried out with the WPO in the most unfavourable condition. All loads and forces have been considered in their most unfavourable combinations.

Rated loads (L_p, L_e, L_b) and structural loads, causing overturning or stabilising moments, have been multiplied by a factor of 1,0 and calculated as acting vertically downwards.

Any horizontal acting load has been multiplied by a factor of 1.1.

To increase the unfavourable loading conditions, only the load arising from the presence of two workers has been considered in order to avoid (lateral overturning analysis) or limit (frontal overturning analysis) any possible stabilising contribution.

In lateral overturning analysis, to increase the unfavourable loading conditions, no bin has been considered, while in frontal overturning analysis only the bin acting as overturning load has been considered.

For wind loads, as stated before, always a more severe shape factor of 1.6 has been considered and they have been considered horizontally acting.

The results of the calculation carried out on the basis of the above-mentioned loads, using the safety criteria previously explained and lever arms reported in Figure 3, are summarized in the following Table 1.

In each considered case the calculated stabilising moment resulted greater than the calculated overturning moments.

Table 1

Overturning calculation analysis results

Overturning analysis	Stabilising moment	Overturning moment	Safety factor
Lateral	19995 Nm	6147 Nm	3.25
Frontal	20123 Nm	13414 Nm	1.50

Conclusions

In conclusion it can be stated that the analysed WPO, originally checked in accordance to the current regulation UNI EN 280, comply also to the upcoming EN 16952.

Even if this is to be considered just a case study, considering the deep approach followed in the analysis, it could be assessed that in most cases the existing WPO should not be redesigned to fulfil the new safety standard.

Acknowledgements

The authors equally contributed to the present study.

References

- [1] Manetto G., Cerruto E., Pascuzzi S., Santoro F. Improvements in citrus packing lines to reduce the mechanical damage to fruit. *Chem. Eng. Trans.* 58, 2017, pp. 391-396. <http://dx.doi.org/10.3303/CET1758066>
- [2] Pascuzzi S., Santoro F. Analysis of possible noise reduction arrangements inside olive oil mills: A case study. *Agriculture (Switzerland)*, 7(10), 2017, 88 p. <http://dx.doi.org/10.3390/agriculture7100088>
- [3] Pascuzzi S., Santoro F. Analysis of the almond harvesting and hulling mechanization process: A case study. *Agriculture (Switzerland)*, 7(12), 2017, 100 p. <http://dx.doi.org/10.3390/agriculture7120100>
- [4] Burkart M.J., McCann M., Paine D.M. Aerial Work Platforms. In: *Elevated Work Platforms and Scaffolding*. McGraw-Hill Companies Inc, New York, 2004, p.239.
- [5] Guo J., He H., Sun C. Analysis of the Performance of Aerial Work Platform Working Device Based on Virtual Prototype and Finite Element Method. *Energy Procedia* 104, 2016, pp. 568-573.
- [6] Kim H.S., Huh H. Vehicle structural collapse analysis using a finite element limit method. *International Journal of Vehicle Design*, 21, 2004, pp. 436-449
- [7] Hongyu T., Ziyi Z. Design and Simulation Based on Pro/E for a Hydraulic Lift Platform in Scissors Type. *Procedia Engineering* 16, 2011, pp. 772-778.
- [8] Pan C.S., A.H., McCann M., Lin M.L., Fearn K., Keane P. Aerial lift fall injuries: A surveillance and evaluation approach for targeting prevention activities. *Journal of Safety Research*, 38(6), 2007, pp. 617-625.
- [9] Aneziris O.N., Papazoglou I.A., Baksteen H., Mud M., Ale B.J., Bellamy L.J., Hale A.R., Bloemhoff A., Post J., Oh J. Quantified risk assessment for fall from height. *Safety Science*, 46 (2), 2008, pp.198-220.
- [10] Simeonov P.I., Hsiao H., Dotson B.W. Ammons D.E. Control and perception of balance at elevated and sloped surfaces. *Human Factors*, 45 (1), 2003, pp. 136-147.
- [11] Ale B.J.M., Baksteen H., Bellamy L.J., Bloemhof A., Goossens L., Hale A., Mud M.L., Oh J.I.H., Papazoglou I.A., Post J., Whiston J.Y. Quantifying occupational risk: The development of an occupational risk model. *Safety Science*, 46 (2), 2008, pp. 176-185.
- [12] Pascuzzi S., Santoro F. Evaluation of farmers' OSH hazard in operation nearby mobile telephone radio base stations. 16th International Scientific Conference "Engineering for rural development" Proceedings, Volume 16. Jelgava, Latvia, May 24-26, 2017, pp. 748-755 – ISSN: 1691-5976, <http://dx.doi.org/10.22616/ERDev2017.16.N15>.

- [13] Das Chagas Moura M., Azevedo R.V., Droguett E.L. Estimation of expected number of accidents and workforce unavailability through Bayesian population variability analysis and Markov-based model. *Reliability Engineering and System Safety*, 150, 2016, pp. 136-146.
- [14] Pascuzzi S., Santoro F. Exposure of farm workers to electromagnetic radiation from cellular network radio base stations situated on rural agricultural land. *International Journal of Occupational Safety and Ergonomics*, 21(3), 2015, pp.351-358.
<http://dx.doi.org/10.1080/10803548.2015.1081774>
- [15] Papazoglou, I.A., Ale, B.J.M. A logical model for quantification of occupational risk. *Reliability Engineering and System Safety*, 92 (6), 2007, pp. 785-803.
- [16] Rakhmatulina A., Kosbolov S., Tanzharikova G. Design of a new load lifting mechanism. *Procedia - Social and Behavioral Sciences* 83, 2013, pp. 689-692.
- [17] Ualiev G.U. Dynamics of Mechanisms and Machines. Almaty: «AGU - Tauar», 2000, p. 282
- [18] Rashida H., Ariffin M.K.A.M., Noh M.H.M., Abdullah A.H., Hamid A.H.A., Jusoh M.A.M., Othman A. Design Review of Scissors Lifts Structure for Commercial Aircraft Ground Support Equipment using Finite Element Analysis. *Procedia Engineering* 41, 2012, pp. 1696–1701.
- [19] Mingzhou S., Qiang G., Bing G. Finite element analysis of steel members under cyclic loading. *Finite Elements in Analysis and Design.*, 39 (1), 2002, pp. 43-54.
- [20] Fathallah F., Cotnam P. J. Impact Forces during Exit from Commercial Vehicles. *Proceedings of the Human Factors and Ergonomics Society Annual Meeting*. 42, 1998, pp. 926-930.
- [21] Pan C.S., Chiou S.S., Kau, T.-Y. Evaluation of postural sway and impact forces during ingress and egress of scissor lifts at elevations. *Applied Ergonomics*, 65, 2017, pp. 152-162.
- [22] Chiou S., Bhattacharya A., Succop P.A., Evaluation of workers' perceived sense of slip and effect of prior knowledge of slipperiness during task performance on slippery surfaces, *American Industrial Hygiene Assoc. Journal (AIHAJ)* 61, 2000, pp. 492-500.
- [23] Bhattacharya A., Succop P., Kincl L., Lu M.N., Bagchee A. Postural stability during task performance on elevated and/or inclined surfaces. *Occupational Ergonomics*, 3 (2), 2002, pp. 83-97.
- [24] Shin G., Mirka G. The effects of a sloped ground surface on trunk kinematics and L5/S1 moment during lifting. *Ergonomics*, 47, 2004, pp. 646-659
- [25] Jiang Z., Shin G., Freeman J., Reid S., Mirka G.A. A study of lifting tasks performed on laterally slanted ground surfaces. *Ergonomics*, 48 (7), 2005, pp. 782-795.
- [26] Anifantis, A.S.; Colantoni, A.; Pascuzzi, S.; Santoro, F. Photovoltaic and Hydrogen Plant Integrated with a Gas Heat Pump for Greenhouse Heating: A Mathematical Study. *Sustainability* 2018, 10, 378. <http://dx.doi.org/10.3390/su10020378>
- [27] Pascuzzi S. A multibody approach applied to the study of driver injuries due to a narrow-track wheeled tractor rollover. *J. Agr. Eng.*, 46, 2015, pp. 105-114.
<http://dx.doi.org/10.4081/jae.2015.466>